

HQ58 拖链—安装尺寸及技术参数 HQ58 Cable Chain—Installation Dimensions and Technical Parameters

架空长度 Unsupported length

- L_G = 直线架空长度
- L_A = 安全塌腰架空长度
- L_G = Unsupported with straight upper run
- L_A = Unsupported with permitted sag

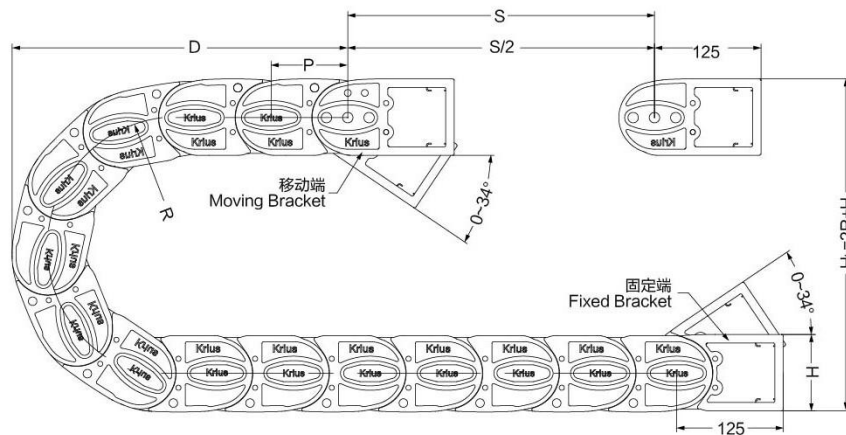
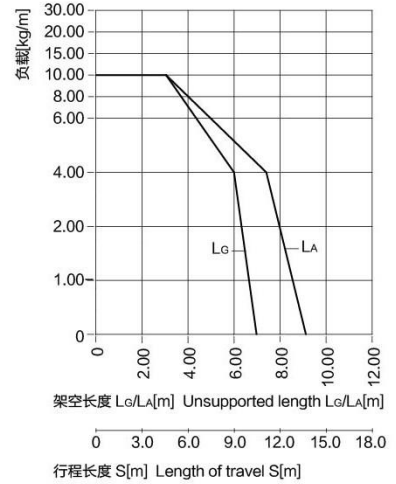
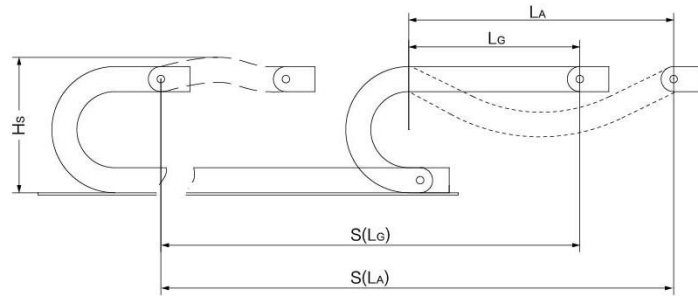

- S = 行程长度
- R = 弯曲半径
- P = 节距
- L = 拖链长度
- N = 每米链节数
- H_L = 理论安装高度
- H_s = 实际安装高度
- D = 拖链退回极限位置时的最小距离
- $K = \pi \cdot R + 2P$
- * K值可在科瑞斯相关表格中直接查询
- S = Length of travel
- R = Bending Radius
- P = Pitch
- L = Length of chain
- N = Links per meter
- H_L = Nominal clearance height
- H_s = Required clearance height
- D = Overlength Energy Chain radius in final position
- $K = \pi \cdot R + 2P$
- * You can find it from below chart for more details

R	H_L	D	K	P
150 (5.91)	390 (15.35)	310 (12.20)	650 (25.59)	90 (3.54)
200 (7.87)	490 (19.29)	410 (16.14)	810 (31.89)	90 (3.54)
250 (9.84)	590 (23.23)	510 (20.08)	965 (37.99)	90 (3.54)
300 (11.81)	690 (27.17)	610 (24.02)	1120 (44.09)	90 (3.54)
400 (15.75)	890 (35.04)	810 (31.89)	1435 (56.50)	90 (3.54)

实际安装高度: $H_s = H_L + 85\text{mm}$
拖链长度: $L = S/2 + K$
每米链节数: $N = 11$ (990mm)

The required clearance height: $H_s = H_L + 3.35\text{in.}$
Chain length: $L = S/2 + K$
Links per meter: $N = 11$ (38.98 in.)

技术参数 Technical Parameters		
速度/加速度 L_G	Speed/acceleration L_G	max.25[m/s]/max.205[m/s ²]
速度/加速度 L_A	Speed/acceleration L_A	max.5[m/s]/max.8[m/s ²]
滑行速度/加速度	Gliding speed/acceleration	max.5[m/s]/max.12[m/s ²]
材料-允许温度 °C	Material-permitted temperature	igumid G/-40°C至+125°C
阻燃等级, igumid G	Flammability Class, igumid G	VDE 0304 IIC UL94 V2

HQ58 拖链-产品规格范围

HQ58 Cable Chain-Product specifications

HQ58拖链-内外侧可开 HQ58 Cable Chain-Inner and outer can be opened

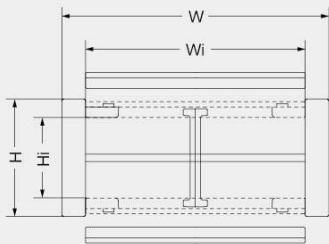

产品代码结构
Part Number Structure

HQ58100*R*L*n

- 数量 (Quantity)
- 拖链长度 (Length of Cable chains)
- 弯曲半径 (Bending Radius)
- 内宽 (Inner Width)
- 型号 (Type)

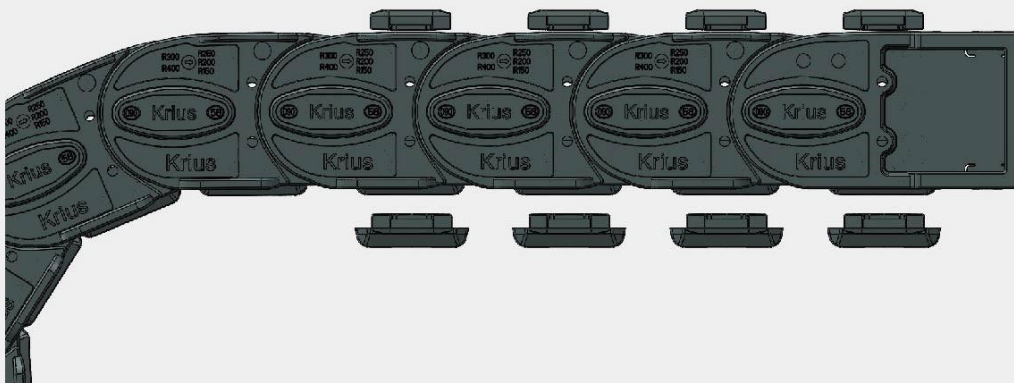

型号 Type	弯曲半径<R> Bending radius	内高<Hi> Inner height	内宽<Wi> Inner width	外高<H> Outer height	外宽<W> Outer Width	重量<G> Weight	备注 Remark
	mm (in.)	mm (in.)	mm (in.)	mm (in.)	mm (in.)	kg/m (lbs/ft)	
HQ58100		59.5 (2.34)	100.2 (3.94)	89.8 (3.54)	140.2 (5.52)	3.85 (2.62)	
HQ58125			125.2 (4.93)		165.2 (6.50)	4.00 (2.72)	
HQ58150			150.2 (5.91)		190.2 (7.49)	4.10 (2.79)	
HQ58200			200.2 (7.88)		240.2 (9.46)	4.45 (3.03)	
HQ58250			250.2 (9.85)		290.2 (11.43)	4.71 (3.20)	
HQ58300			300.2 (11.82)		340.2 (13.39)	5.04 (3.43)	
HQ58350			350.2 (13.79)		390.2 (15.36)	5.40 (3.67)	
HQ58400			400.2 (15.76)		440.2 (17.33)	5.63 (3.83)	

订货范例
Order details

HQ58100 * R150 * 1000mm * 2

R	Hi	D	K	P
150 (5.91)	390 (15.35)	310 (12.20)	650 (25.59)	90 (3.54)
200 (7.87)	490 (19.29)	410 (16.14)	810 (31.89)	90 (3.54)
250 (9.84)	590 (23.23)	510 (20.08)	965 (37.99)	90 (3.54)
300 (11.81)	690 (27.17)	610 (24.02)	1120 (44.09)	90 (3.54)
400 (15.75)	890 (35.04)	810 (31.89)	1435 (56.50)	90 (3.54)

HQ58 拖链-拖链接头 HQ58 Cable Chain-Mounting Bracket

塑料接头或钢制接头，分体式 Plastic or Steel Mounting Bracket, Splitted structure

- 双侧独立式塑料接头或钢制接头
- 两端接头均可活动
- 耐腐蚀 & 耐摩擦
- 可提供预装配形式
- 可实现内外连接
- Independent Plastic or Steel mounting bracket on the two end
- Moved connectors on both sides
- Anti-corrosion, Rub-resistance
- Available preassembly form
- Can realize the internal and external connections

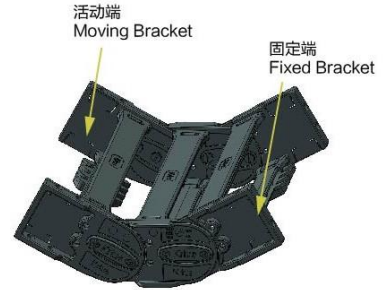

可选配的接头安装方式 Available installation methods

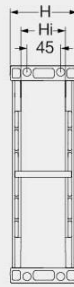
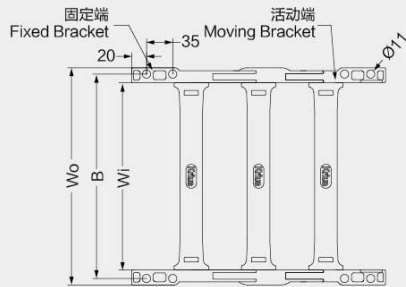
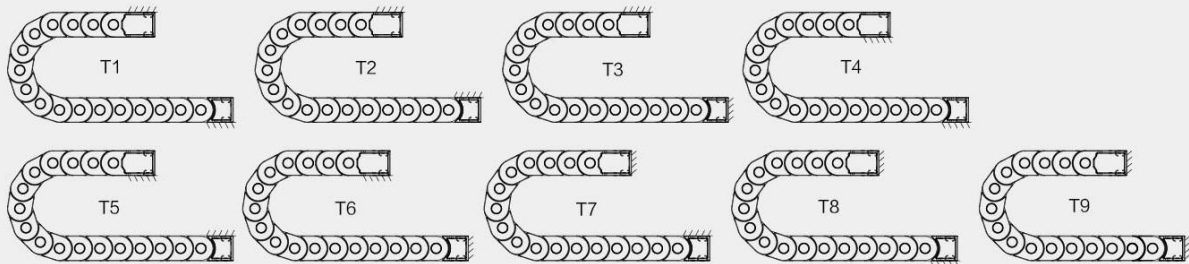

HQ58100/HQ58125
HQ58150/HQ58200
HQ58250/HQ58300
HQ58350/HQ58400

拖链型号 Type	拖链编码 Code	其他编码 Other Code			Wo尺寸 Dimension Wo mm (in.)	B尺寸 Dimension B mm (in.)
HQ58100	11200				140.2 (5.52)	123.2 (4.85)
HQ58125	11255				165.2 (6.50)	148.2 (5.83)
HQ58150	11201	接头 Mounting Bracket	14131	隔离片 Separator	190.2 (7.49)	173.2 (6.82)
HQ58200	11191		14132	固定片 Fixed Plate	240.2 (9.46)	223.2 (8.79)
HQ58250	11202	主体 Main Body Code	11243		290.2 (11.43)	273.2 (10.76)
HQ58300	11203				340.2 (13.39)	323.2 (12.72)
HQ58350	11204				390.2 (15.36)	373.2 (14.69)
HQ58400	11205				440.2 (17.33)	423.2 (16.66)

产品代码结构 Part Number Structure

HQ58100*B*T1



- HQ58100*B*T1*n 两端接头
On both brackets
- HQ58100*f*T1*n 固定端接头
Fixed bracket
- HQ58100*m*T1*n 移动端接头
Moving bracket

★ 每款拖链的接头都有所不同，订购时如有任何疑问，请及时咨询科瑞斯。
Every bracket is different, please contact us if you have any question.



HQ58 Cable Chain
HQ58 拖链

HQ58 拖链-隔离片

HQ58 Cable Chain-Separator

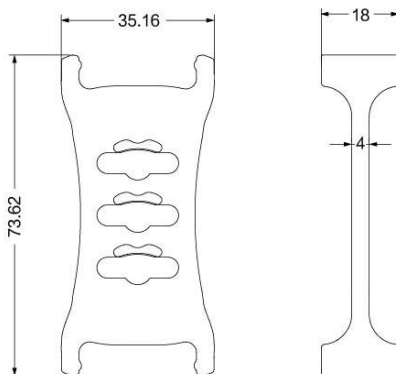

HQ58拖链隔离片编码: 11246
The separator No. for HQ58: 11246

- 本款拖链标配隔离片为竖隔片, 可以实现垂直分隔, 也可订制铝杆作为横隔片, 实现水平分隔
- 竖隔片的数量可以根据客户的实际需求进行配备, 可以每隔一个链节装一个, 也可以每隔一个链节装几个, 客户可任意配备
- 竖隔片安装完成后, 可以根据线缆排布进行滑动
- The standard separator is vertical direction which can make the vertical division, and also we can customize horizontal Al separator for horizontal division
- Vertical separators can be placed into each link or different quantity links, it can be customized
- Separator can be moved for different cable