

ZHQ62 拖链-安装尺寸及技术参数 ZHQ62 Cable Chain-Installation Dimensions and Technical Parameters

架空长度

Unsupported length

- L_G = 直线架空长度
- L_A = 安全塌腰架空长度
- L_G = Unsupported with straight upper run
- L_A = Unsupported with permitted sag

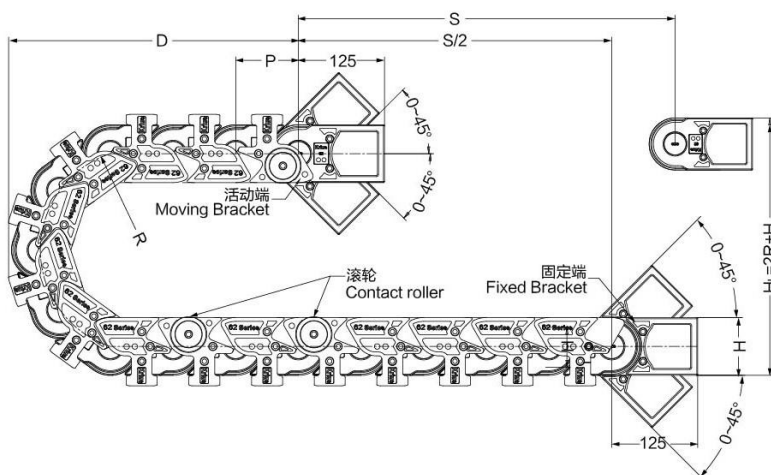
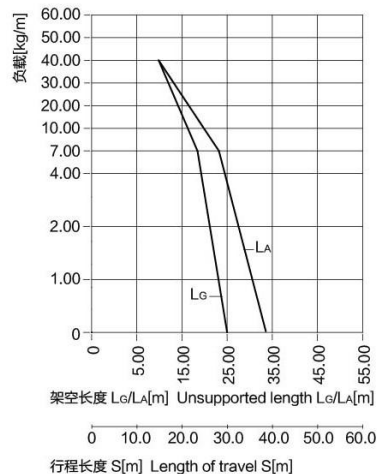
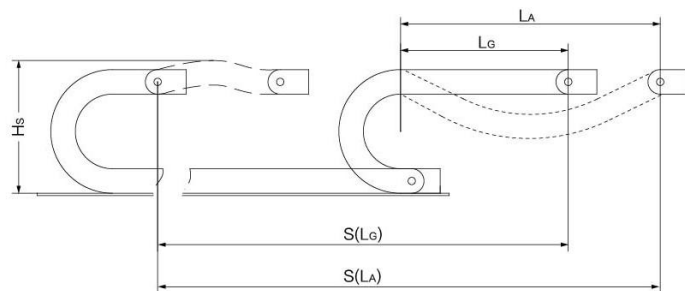

- S = 行程长度
- R = 弯曲半径
- P = 节距
- L = 拖链长度
- N = 每米链节数
- H_L = 理论安装高度
- H_s = 实际安装高度
- D = 拖链退回极限位置时的最小距离
- $K = \pi \cdot R + 2P$
- * K值可在科瑞斯相关表格中直接查阅
- S = Length of travel
- R = Bending Radius
- P = Pitch
- L = Length of chain
- N = Links per meter
- H_L = Nominal clearance height
- H_s = Required clearance height
- D = Overlength Energy Chain radius in final position
- $K = \pi \cdot R + 2P$
- * You can find it from below chart for more details

R	H _L	D	K	P
150 (5.91)	406 (15.98)	310 (12.20)	670 (26.38)	98 (3.86)
200 (7.87)	506 (19.92)	410 (16.14)	825 (32.48)	98 (3.86)
250 (9.84)	606 (23.86)	510 (20.08)	980 (38.58)	98 (3.86)
300 (11.81)	706 (27.80)	610 (24.02)	1140 (44.88)	98 (3.86)
350 (13.78)	806 (31.73)	710 (27.95)	1295 (50.98)	98 (3.86)
400 (15.75)	906 (35.67)	810 (31.89)	1450 (57.09)	98 (3.86)
500 (19.69)	1106 (43.54)	1010 (39.76)	1765 (69.49)	98 (3.86)
600 (23.62)	1306 (51.42)	1210 (47.64)	2080 (81.89)	98 (3.86)
650 (25.59)	1406 (55.35)	1310 (51.57)	2240 (88.19)	98 (3.86)
1000 (39.37)	2106 (82.92)	2010 (79.13)	3335 (131.30)	98 (3.86)

实际安装高度: $H_s = H_L + 100\text{mm}$
拖链长度: $L = S/2 + K$
每米链节数: $N = 10$ (980mm)

The required clearance height: $H_s = H_L + 3.94\text{in.}$
Chain length: $L = S/2 + K$
Links per meter: $N = 10$ (38.58 in.)

技术参数 Technical Parameters		
速度/加速度 L_G	Speed/acceleration L_G	max.25[m/s]/max.205[m/s ²]
速度/加速度 L_A	Speed/acceleration L_A	max.5[m/s]/max.8[m/s ²]
滑行速度/加速度	Gliding speed/acceleration	max.5[m/s]/max.12[m/s ²]
材料-允许温度 °C	Material-permitted temperature	igumid G/-40°C至+125°C
阻燃等级, igumid G	Flammability Class, igumid G	VDE 0304 IIC UL94 V2

ZHQ62 拖链-产品规格范围 ZHQ62 Cable Chain-Product specifications

ZHQ62拖链-内外侧可开 ZHQ62 Cable Chain-Inner and outer can be opened

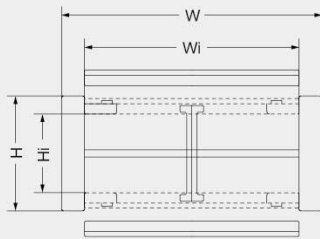

产品代码结构
Part Number Structure

ZHQ62100*R*L*n

- └─ 数量 (Quantity)
- └─ 拖链长度 (Length of Cable chains)
- └─ 弯曲半径 (Bending Radius)
- └─ 内宽 (Inner Width)
- └─ 型号 (Type)

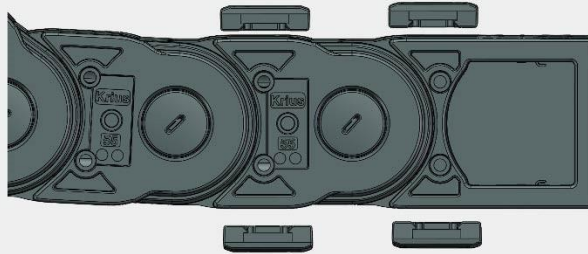

型号 Type	弯曲半径<R> Bending radius	内高<Hi> Inner height	内宽<Wi> Inner width	外高<H> Outer height	外宽<W> Outer Width	重量<G> Weight	备注 Remark
ZHQ6275	mm (in.)		75 (2.95)		169 (6.65)	4.24 (2.88)	
ZHQ62100			100 (3.94)		194 (7.64)	4.44 (3.02)	
ZHQ62125			125 (4.92)		219 (8.62)	4.64 (3.16)	
ZHQ62150			150 (5.91)		244 (9.61)	5.00 (3.40)	
ZHQ62175			175 (6.89)		279 (10.98)	5.35 (3.64)	
ZHQ62200			200 (7.87)		294 (11.57)	5.72 (3.89)	
ZHQ62250			250 (9.84)		344 (13.54)	6.12 (4.16)	
ZHQ62300		62 (2.44)	300 (11.81)	106 (4.17)	394 (15.51)	6.52 (4.43)	
ZHQ62350			350 (13.78)		444 (17.48)	6.93 (4.71)	
ZHQ62400			400 (15.75)		494 (19.45)	7.35 (5.00)	
ZHQ62450			450 (17.72)		544 (21.42)	9.79 (6.66)	
ZHQ62500			500 (19.69)		594 (23.39)	10.29 (7.00)	
ZHQ62550			550 (21.65)		644 (25.35)	10.99 (7.47)	
ZHQ62600			600 (23.62)		694 (27.32)	11.55 (7.85)	

订货范例
Order details

ZHQ62150 * R200 * 1000mm * 2

R	Hi	D	K	P
150(5.91)	406 (15.98)	310 (12.20)	670 (26.38)	98 (3.86)
200(7.87)	506 (19.92)	410 (16.14)	825 (32.48)	98 (3.86)
250(9.84)	606 (23.86)	510 (20.08)	980 (38.58)	98 (3.86)
300(11.81)	706 (27.80)	610 (24.02)	1140 (44.88)	98 (3.86)
350(13.78)	806 (31.73)	710 (27.95)	1295 (50.98)	98 (3.86)
400(15.75)	906 (35.67)	810 (31.89)	1450 (57.09)	98 (3.86)
500(19.69)	1106 (43.54)	1010 (39.76)	1765 (69.49)	98 (3.86)
600(23.62)	1306 (51.42)	1210 (47.64)	2080 (81.89)	98 (3.86)
650(25.59)	1406 (55.35)	1310 (51.57)	2240 (88.19)	98 (3.86)
1000(39.37)	2106 (82.92)	2010 (79.13)	3335 (131.30)	98 (3.86)

ZHQ62 拖链-拖链接头 ZHQ62 Cable Chain-Mounting Bracket

塑料接头，分体式 Plastic Mounting Bracket, Splitted structure

- 双侧独立式塑料接头
 - 两端接头均可双向活动
 - 耐腐蚀 & 耐摩擦
 - 可提供预装配形式
 - 可实现内外连接
- Independent Plastic mounting bracket on the two end
 - Two end mounting bracket can be movable to upper and lower
 - Anti-corrosion, Rub-resistance
 - Available preassembly form
 - Can realize the internal and external connections

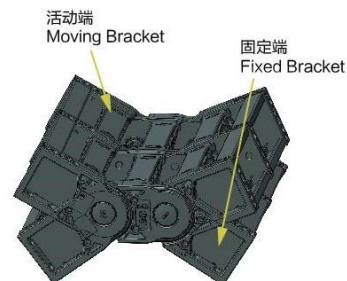

可选配的接头安装方式 Available installation methods

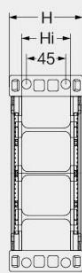
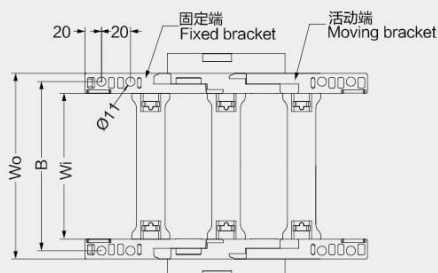
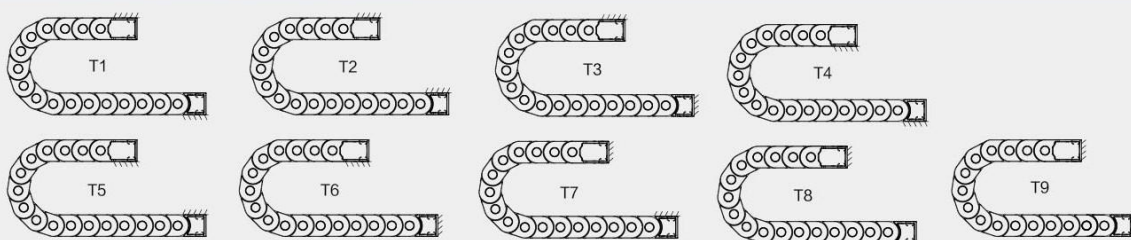

ZHQ6275 / ZHQ62100 / ZHQ62125 / ZHQ62150 / ZHQ62175
ZHQ62200 / ZHQ62250 / ZHQ62300 / ZHQ62350 / ZHQ62400
ZHQ62500 / ZHQ62550 / ZHQ62600

拖链型号 Type	拖链编码 Code	其他编码 Other Code	Wo尺寸 Dimension Wo	B尺寸 Dimension B
			mm (in.)	mm (in.)
ZHQ6275	13074	接头 Fixed plate	119 (4.69)	97 (3.82)
ZHQ62100	13075	13124	144 (5.67)	122 (4.80)
ZHQ62125	13076	主体 Separator	169 (6.65)	147 (5.79)
ZHQ62150	13077	13123	194 (7.64)	172 (6.77)
ZHQ62175	13078	竖隔离片 Vertical separator	219 (8.62)	197 (7.76)
ZHQ62200	13079	13126	244 (9.60)	222 (8.74)
ZHQ62250	13080	横隔离片 Horizontal separator	294 (11.57)	272 (10.71)
ZHQ62300	13093	13087	344 (13.54)	322 (12.68)
ZHQ62350	13085	L400隔离杆 Separator of Length with 400mm	394 (15.51)	372 (14.65)
ZHQ62400	13102	13090	444 (17.48)	422 (16.61)
ZHQ62450	13103	滚轮 Contact roller	494 (19.45)	472 (18.58)
ZHQ62500	13104	13154	544 (21.42)	522 (20.55)
ZHQ62550	13104	轴销 Axle pin	594 (23.39)	572 (22.52)
ZHQ62600	13104	13092	644 (25.35)	622 (24.49)

产品代码结构 Part Number Structure

ZHQ62100*B*T1

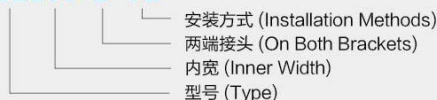

- ZHQ62100*B*T1*n 两端接头
On both brackets
- ZHQ62100*f*T1*n 固定端接头
Fixed bracket
- ZHQ62100*m*T1*n 移动端接头
Moving bracket

★ 每款拖链的接头都有所不同，订购时如有任何疑问，请及时咨询科瑞斯。
Every bracket is different, please contact us if you have any question.

ZHQ62 拖链-隔离片 ZHQ62 Cable Chain-Separator

- 本款拖链配备的隔离元件为横隔离（插）片和竖隔离（插）片，可以实现垂直分割和水平分隔
- 隔离元件的数量可以根据客户的实际需求进行配备
- 竖隔（插）片可以根据线缆排布进行滑动
- The isolation element is equipped with horizontal chain (plug) and vertical isolation (plug), you can achieve vertical segmentation and horizontal partitioning
- The number of isolated components can be equipped according to the actual needs of customers
- Vertical separator can be moved for different cables

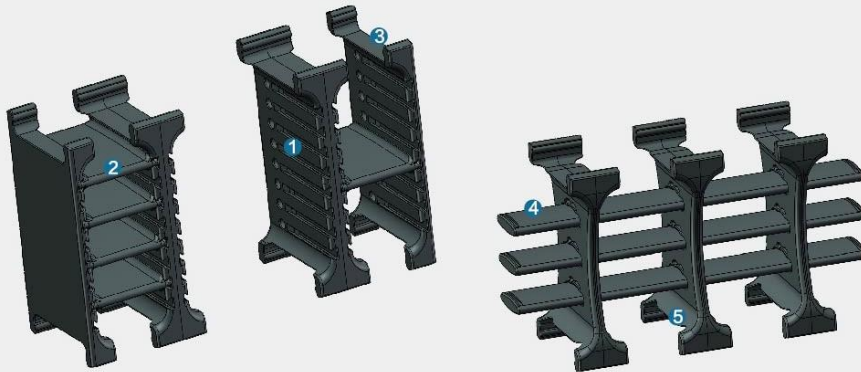
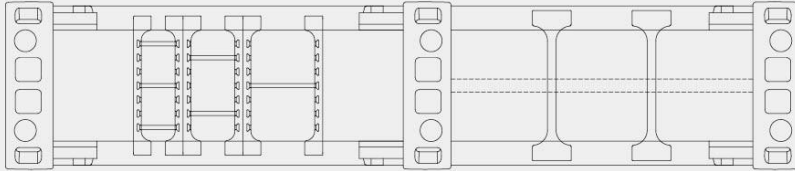

单位: mm

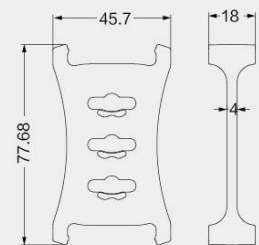
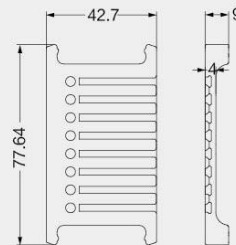
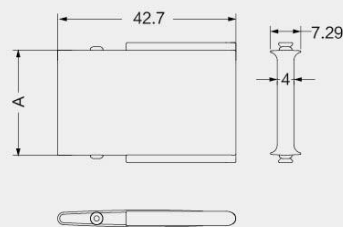
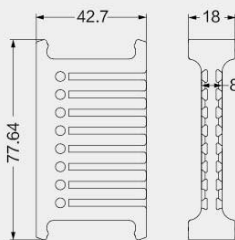

ZHQ62隔离元件编码
The separator NO. for ZHQ62 :

- | | |
|---------------------------------|-------|
| ① 竖隔离片 (Vertical Separator) | 13126 |
| ② 横隔插片 (Transverse Septum) | 13087 |
| ③ 竖隔离片 (Vertical Separator) | 13126 |
| ④ 横隔离片 (Horizontal Separator) | 13127 |
| ⑤ 竖隔离片 (Vertical Separator) | 13126 |

注: ①②③之间的距离可以为25mm、30mm、40mm、50mm、60mm、70mm
Note: (1) (2) (3) the distance between the 25mm、30mm、40mm、50mm、60mm、70mm