

卧加防护罩订购参数表及回执单
Integrated backwall guard order details

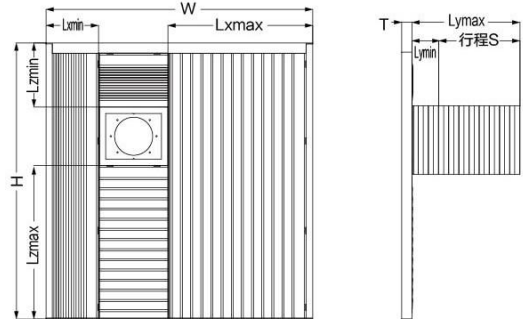

参数代码 Code	参数名称 Des	参数值 Figure	检测结果(我司填写) Test result by Krius	备注 Remark	说明 Remark
Lxmax	X轴最大拉伸 X axle max stretched out length				机床的运行范围 (必填) Machine travel range (Not null)
Lxmin	X轴最小压缩 X axle mix compressed length				
Lymax	Y轴最大拉伸 Y axle max stretched out length				
Lymin	Y轴最小压缩 Y axle mix compressed length				
Lzmax	Z轴最大拉伸 Z axle max stretched out length				
Lzmin	Z轴最小压缩 Z axle mix compressed length				
S	防护罩行程 (X/Y/Z) Travel distance for x/y/z				机床的最大行程 (可选) Machine max distance (Optional)
W	横梁宽度 Transom width				必填 Not null
H	立柱高度 Upright height				必填 Not null
T	横梁/立柱厚度 Transom/upright thickness				≥ 70mm (必填) ≥ 70mm (Not null)
	附件选配 Accessories need				可选 Optional
	防护罩材质 material of cover				材质/表面处理 (可选) Material and surface treatment (Optional)
	导轨型号 Guide rail item No.		-		型号或尺寸 (附图) (必填 Not null / attached)
	机床运行速度 Running speed		-		必填 Not null
	安装方式 Assemble way		-		水平/垂直/其它 (可选) Vertical/horizontal/others (Optional)
	安装机台型号 Equipment item No.		-		可选 Optional
	使用环境 Enviornent		-		是否有大量碎屑 (可选) Scrap or not (Optional)
订货单位 Company name			送货地址 Company address		
联系方式 Contact way			送货方式 Shipping way	<input type="checkbox"/> 空运 Air <input type="checkbox"/> 加急 Urgent	<input type="checkbox"/> 陆运 Freight <input type="checkbox"/> 其它 Others _____
• 用户订货时只要填写上方阴影部分 (数据或材质) 或直接发送图纸, 我司方可进行设计 It is better to offer the drawings(or mark above figure) then Krius design exactly • 如果客户所需护罩有特殊说明, 请在备注栏填写或直接与我司进行联系沟通; 若无要求, 则按照我司标准制作 Pls remark if you have speical demand, or we will follow Krius regulation • 导轨部分若客户提供尺寸, 请附图说明 If you have the guide rail drawing, pls atthced • 上述参数若为客户方测量或设计, 请注明是否留有余量 Pls mark whether there are margin when you supply the parameter • 我方在送货时会将此单随产品一起发出 We will take the order details with goods shippment together					

★ 如有特殊要求增加附件, 请参照附表一(附件选配表)

柔性风琴式防护罩

Flexible Accordion Bellows

该类型防护罩呈现多种变化形态，可以根据机床安装要求的变化而随之改变。
It has so many different structure and It need to be customized

基本形状 Basic structure

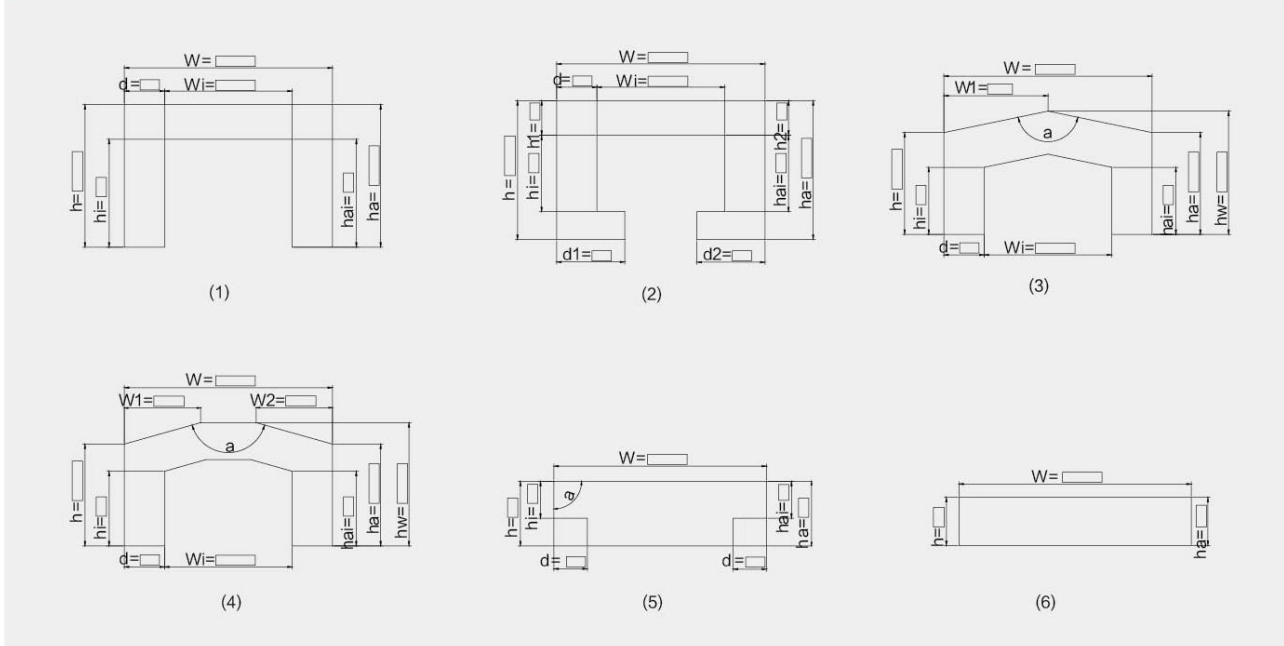

异形防护罩 Special shaped bellow cover

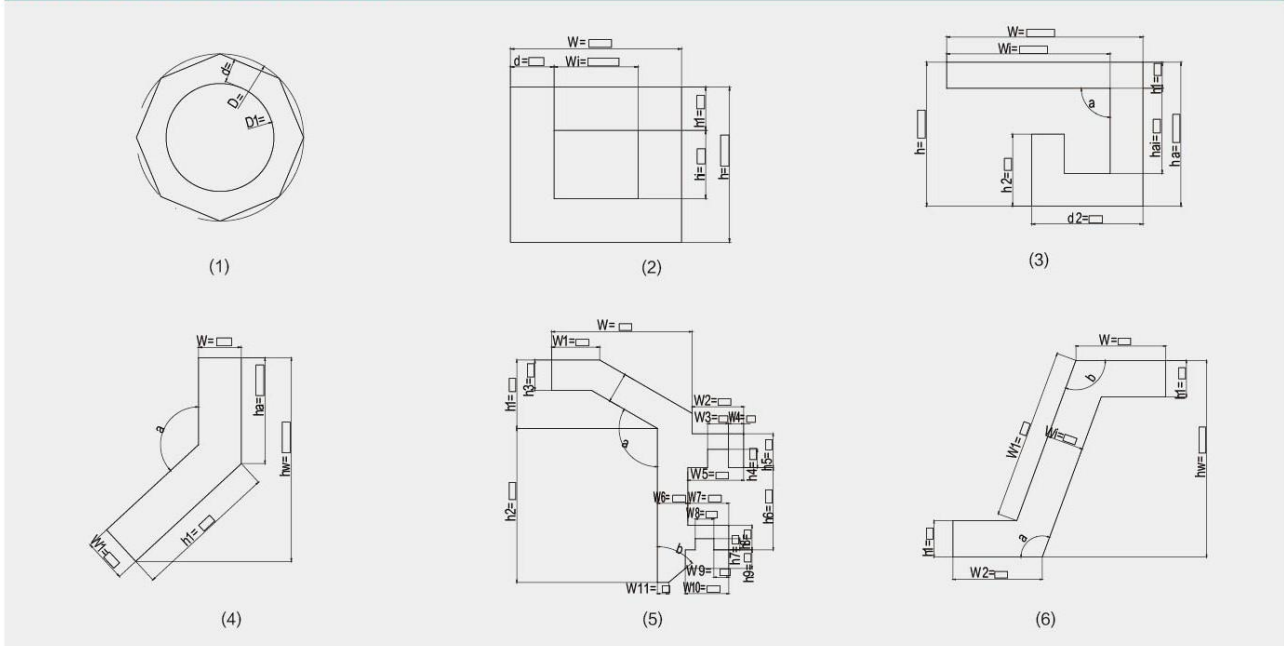

★ 我公司生产制作的防护罩，可以根据不同的客户需求提供满足要求的产品，如有任何疑问，请及时向 **Krius®** 人员进行咨询
All can be customized. Contact our staff if you have any query

柔性风琴式防护罩订购参数表及回执单 Flexible bellow order details

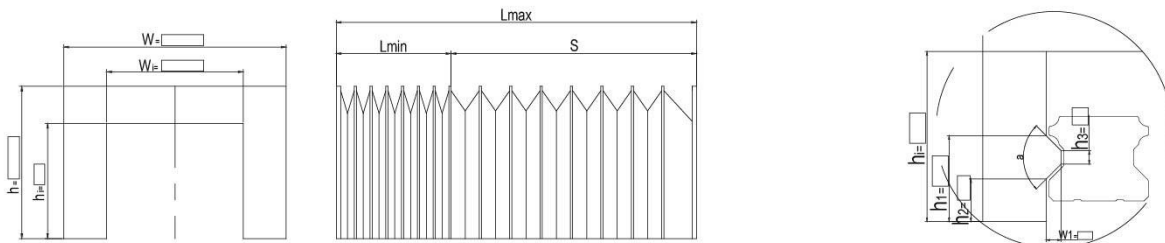

参数代码 Code	参数名称 Des	参数值 Figure	检测结果(我司填写) Test result by Krius	备注 Remark	说明 Remark
Lmax	防护罩最大拉伸 Stretched out length				机床的运行范围 (必填) Machine travel range (Not null)
Lmin	防护罩最小压缩 Compressed length				
S	防护罩行程 Travel distance				机床的最大行程 (可选) Machine max distance (Optional)
W	防护罩外宽 Outer width				必填 Not null
Wi	防护罩内宽 Inner width				必填 Not null
h	防护罩外高 Outer height				必填 Not null
hi	防护罩内高 Inner height				必填 Not null
H	防护罩折高 Folding height				范围:10mm-55mm (可选) Range:10mm-55mm (Optional)
B	连接法兰 Flange material				材质/表面处理 (可选) Material and surface treatment (Optional)
	防火要求 Fire-resistant or not	<input type="checkbox"/> 是Yes <input type="checkbox"/> 否No	<input type="checkbox"/> 是Yes <input type="checkbox"/> 否No		可选 Optional
	导轨型号 Guide rail item No.		-		型号或尺寸 (附图) (必填 Not null / attached)
	机床运行速度 Running speed		-		可选 Optional
	安装方式 Assemble way		-		水平/垂直/其它 (可选) Vertical/horizontal/others (Optional)
	安装机台型号 Equipment item No.		-		可选 Optional
	使用环境 Enviroment		-		是否有大量碎屑 (可选) Scrap or not (Optional)
订货单位 Company name			送货地址 Company address		
联系方式 Contact way			送货方式 Shipping way	<input type="checkbox"/> 空运 Air <input type="checkbox"/> 加急 Urgent	<input type="checkbox"/> 陆运 Freight <input type="checkbox"/> 其它 Others _____
<ul style="list-style-type: none"> 用户订货时只要填写上方阴影部分 (数据或材质) 或直接发送图纸, 我司方可进行设计 It is better to offer the drawings(or mark above figure) then Krius design exactly 如果客户所需护罩有特殊说明, 请在备注栏填写或直接与我司进行联系沟通; 若无要求, 则按照我司标准制作 Pls remark if you have speical demand, or we will follow Krius regulation 导轨部分若客户提供尺寸, 请附图说明 If you have the guide rail drawing, pls attchcd 上述参数若为客户方测量或设计, 请注明是否留有余量 Pls mark whether there are margin when you supply the parameter 我方在送货时会将此单随产品一起发出 We will take the order details with goods shippment together 					

★ 如有特殊要求增加附件,请参照附表一(附件选配表)

风琴防护罩技术参数示意图
Flexible accordion bellow parameter diagram

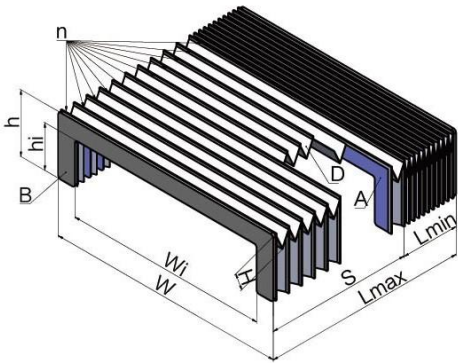

Lmax=防护罩的最大拉伸
Lmin=防护罩的最小压缩
S=行程长度
W=防护罩外宽
Wi=防护罩内宽
h=防护罩外高
hi=防护罩内高
H=防护罩的折高
n=防护罩的折数
D=防护罩的布料
A=防护罩骨架
B=防护罩两端法兰

Lmax=Ma stretched out length
Lmin=Compressed length
S=Lmin Travel distance
W=outer width
Wi=Inner width
h=Outer height
hi=Inner height
H=Folding height
n=Folding qty
D=Bellow fabric
A=Bellow supporter
B=Two end flange

★ $H \leq h - h_i$ 或 $H \leq (W - W_i) / 2$ (两侧对称); 若无特殊说明, 防护罩两端法兰均采用Q235材质
 $H \leq h - h_i$ or $H \leq (W - W_i) / 2$ (two side symmetry); We will use Q235 for two end flange if no special demand

